

ABC

di Q18

sistema di fissaggio
intelligente e ampia gamma di
colori

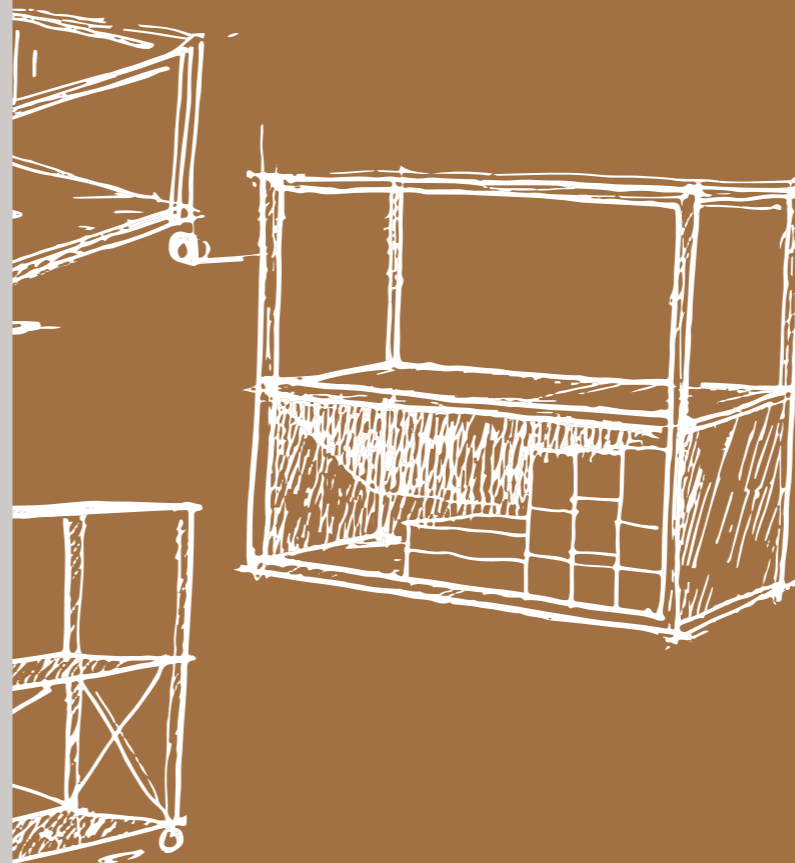

Q18 ABC
intelligent fixing system
and wide range of
colours

ABC du Q18
système de fixation
intelligent et large gamme
de couleurs

ABC del Q18
sistema de fijación
inteligente y amplia gama
de colores

/unicità

Il design unico del sistema di librerie Q18, è l'equilibrio perfetto tra complanarità dei componenti, libertà di layout e molteplici opzioni di colore. Sottile, elegante e personalizzabile, questo è Q18.

***Uniqueness** the unique design of the Q18 shelving system is the perfect balance between flushness of components, layout freedom and multiple colour options. Thin, elegant and customizable, this is Q18.*

***Unicité** le design unique du système d'étagères Q18 est l'équilibre parfait entre la fluidité des composants, la liberté d'agencement et les multiples options de couleurs. Mince, élégant et personnalisable, c'est le Q18.*

***Único** el diseño único de la estantería Q18 es el equilibrio perfecto entre la coplanaridad de los componentes, la libertad de distribución y las múltiples opciones de color. Fino, elegante y personalizable, este es Q18.*



/minimalismo intelligente

Q18 è una soluzione modulare composta da una struttura in tubolare di alluminio con sezione 18x18 mm, alla quale vengono integrati pannelli e moduli contenitori. Il sistema di fissaggio intelligente che unisce le parti in alluminio rende questo prodotto elegante e pulito, senza viti a vista.



***Smart minimalism** Q18 is a modular solution consisting of a tubular aluminium structure with 18x18 mm section, to which panels and container modules are integrated. The intelligent fixing system that combines the aluminium parts makes this product elegant and clean, without visible screws.*

***Minimalisme intelligent** Q18 est une solution modulaire constituée d'une structure tubulaire en aluminium de section 18x18 mm, à laquelle sont intégrés des panneaux et des modules de conteneurs. Le système de fixation intelligent qui combine les pièces en aluminium rend ce produit élégant et propre, sans vis apparentes.*

***Minimalismo inteligente** Q18 es una solución modular que consiste en una estructura tubular de aluminio de sección 18x18 mm, a la que se integran paneles y módulos de contenedores. El sistema de fijación inteligente que combina las piezas de aluminio hace que este producto sea elegante y limpio, sin tornillos visibles.*



/modularità

Q18 è pensato per rispondere alle più svariate esigenze d'arredo. Per i moduli si può scegliere infatti tra 8 diverse larghezze, 3 profondità e 2 altezze. Schiene e fianchi possono essere sostituiti da tiranti in acciaio che sostengono la struttura conferendole anche un'alternativa estetica.



***Modularity** Q18 is designed to meet the most varied furnishing requirements. For the modules you can choose between 8 different widths, 3 depths and 2 heights. Back and sides can be replaced by steel tie rods that support the structure, giving it an aesthetic alternative.*

***Modularité** Q18 est conçu pour répondre aux besoins d'ameublement les plus variés. Pour les modules, vous pouvez choisir entre 8 largeurs différentes, 3 profondeurs et 2 hauteurs. Le dos et les côtés peuvent être remplacés par des tirants en acier qui soutiennent la structure, ce qui lui donne une alternative esthétique.*

***Modularidad** Q18 está diseñado para satisfacer las más variadas necesidades de mobiliario. Para los módulos se puede elegir entre 8 anchos diferentes, 3 profundidades y 2 alturas. La parte trasera y los laterales pueden ser sustituidos por tirantes de acero que soportan la estructura, dándole una alternativa estética.*

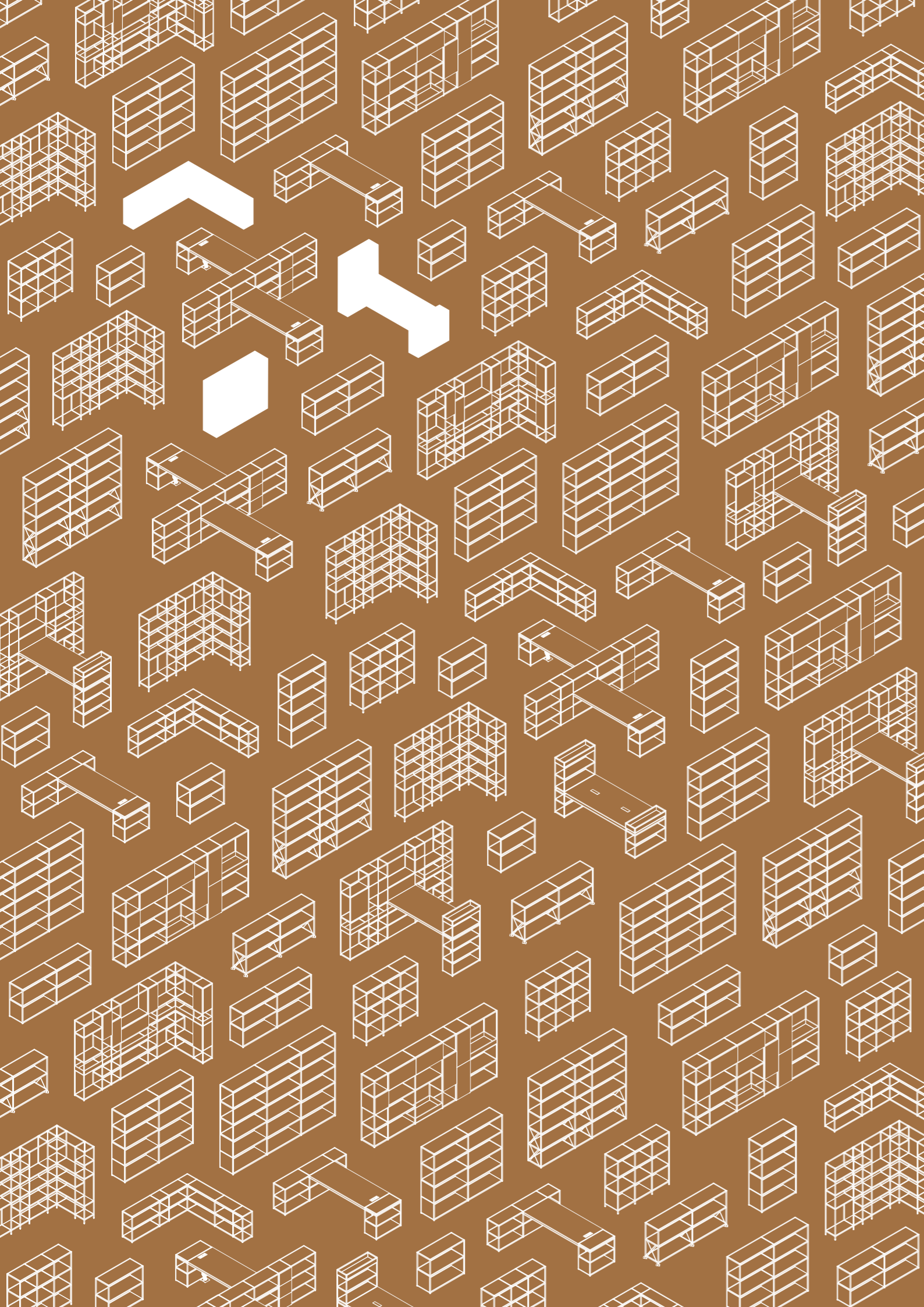

INFINITE POSSIBILITÀ DI LAYOUT

spunti e appunti

Endless layout
possibilities:
hints and notes

Infinies possibilités
de layout:
conseils et notes

Infinitas posibilidades
de diseño:
consejos y notas





***l elements** the Q18 compositions can be integrated with different types of elements. Shelves, backs, sides, drawer units, container modules with hinged and flap doors, planter boxes can be added to the structure to better adapt to the practical needs of users.*

***l éléments** les compositions du Q18 peuvent être intégrées avec différents types d'éléments. Des étagères, des dossiers, des côtés, des tiroirs, des modules de conteneurs avec des portes à charnières et à rabat, des plateaux à plantes peuvent être ajoutés à la structure pour mieux s'adapter aux besoins pratiques des utilisateurs.*

***l elementos** las composiciones Q18 pueden ser integradas con diferentes tipos de elementos. Estantes, respaldos, laterales, cajoneras, módulos contenedores con puertas batientes y abatibles, bandejas para plantas se pueden añadir a la estructura para adaptarse mejor a las necesidades prácticas de los usuarios.*

/elementi

Le composizioni Q18 si possono integrare con diverse tipologie di elementi. Ripiani, schiene, fianchi, cassettiere, moduli contenitori con ante battenti e a ribalta, vaschette porta piante possono essere aggiunti alla struttura per meglio adattarsi alle esigenze pratiche degli utilizzatori.



/opzioni

In base all'altezza e alla profondità scelta, Q18 si può utilizzare come sistema indipendente, piuttosto che fissato al muro oppure al soffitto. Anche l'appoggio a terra è disponibile in diverse opzioni: piedini bassi o rialzati oppure su ruote.

Options depending on the height and depth chosen, Q18 can be used as a stand-alone system, rather than fixed to the wall or ceiling. The floor support is also available in different options: low or raised feet or on castors.

Options selon la hauteur et la profondeur choisies, Q18 peut être utilisé comme un système autonome, plutôt que d'être fixé au mur ou au plafond. Le support au sol est également disponible en différentes options : pieds bas ou surélevés ou sur roulettes.

Opciones dependiendo de la altura y la profundidad elegidas, Q18 puede utilizarse como un sistema autónomo, en lugar de fijarse a la pared o al techo. El apoyo al suelo también está disponible en diferentes opciones: pies bajos o elevados o sobre ruedas.



/essenzialità

Le ante dei contenitori sono progettate con sistema di apertura "push and pull" per marcarne ulteriormente il design minimalista.



***/essentiality** closed storage is fitted with push-pull closures so no handles are required maintaining a clean aesthetic.*

***/essentialité** les portes des conteneurs sont conçues avec un système d'ouverture par poussée et traction pour marquer davantage leur conception minimaliste.*



***/esencialidad** las puertas de los contenedores están diseñadas con un sistema de apertura de empujar y tirar para marcar aún más su diseño minimalista.*

Q18



/cassettiere

Q18 può essere implementato con cassettiere integrate, sia nella versione con cassetti singoli che con classificatori, entrambi con presa orizzontale.

***/drawers** Q18 integrates both filling and box drawers, delivering practical and efficient storage with a clean, full width pull handle.*

***/blocs-tiroirs** Q18 peut être mis en œuvre avec des blocs-tiroirs intégrés, aussi bien dans la version à tiroirs simples que dans celle à classificateurs, tous deux avec prise horizontale.*

***/cajoneras** Q18 se puede realizar con cajoneras integradas, tanto en la versión con cajones individuales como en la versión con archivadores, ambas con agarre horizontal.*



/libertà di layout

Questa collezione ha la capacità di adattarsi a qualsiasi tipo di ambiente e soluzione d'arredo. Quasi nessun limite alla creatività, con soluzioni lineari o articolate che permettono di ottenere le più svariate geometrie.



Layout freedom this collection has the ability to adapt to any type of environment and furnishing solution. Almost no limits to creativity with linear runs or returns also incorporating worksurfaces at desk or standing height

liberté de configuration cette collection a la capacité de s'adapter à tout type d'environnement et de solution d'ameublement. Presque aucune limite à la créativité, avec des solutions linéaires ou articulées qui permettent d'obtenir les géométries les plus variées.

libertad de configuración esta colección tiene la capacidad de adaptarse a cualquier tipo de entorno y solución de mobiliario. Casi sin límites a la creatividad, con soluciones lineales o articuladas que permiten obtener las más variadas geometrías.



/palette di colori

l'ampia gamma di finiture e colori disponibili è il tocco finale. 17 diverse opzioni melaminiche per gli elementi pannellati, da abbinare alla struttura in metallo (in 11 diverse vernici epossidiche) per creare il miglior progetto personalizzato.



***l colour palette** the wide range of finishes and colours available is the finishing touch. 17 different melamine options for the panelled elements, to be combined with the metal structure (in 11 different epoxy paints) to create the best custom design.*

***l palette de couleurs** la large gamme de finitions et de couleurs disponibles est la touche finale. 17 options différentes de mélamine pour les éléments lambrissés, à combiner avec la structure métallique (dans 11 peintures époxy différentes) pour créer le meilleur design personnalisé.*

***l paleta de colores** la amplia gama de acabados y colores disponibles es el toque final. 17 opciones diferentes de melamina para los elementos panelados, que se pueden combinar con la estructura metálica (en 11 pinturas epoxídicas diferentes) para crear el mejor diseño personalizado.*

EPX pag.37

struttura in alluminio verniciato
epoxy painted aluminium structure
structure en aluminium peinte
estructura de aluminio pintado

sezione quadrata 18x18 mm
square section 18x18 mm (11/16")



MEL pag.37

pannelli
panels
panneaux
paneles

Schiene e fianchi

disponibili anche nella versione con tiranti in metallo
Backs and sides also available in the version with metal tie rods

Dos et hanches également disponible dans la version avec tirants métalliques

Traseras y laterales: también disponibles en la versión con tirantes metálicos



1.

2.

3.

supporto 1. piedino esagonale (18 mm), 2. piedino esagonale rialzato (82 mm), 3. ruota (Ø 40 mm)
support: 1. hexagonal foot (18 mm - 11/16"), 2. raised hexagonal foot (82 mm - 3 1/4"), 3. castor (Ø 40 mm - 1 9/16")

support: 1. pied hexagonal (18 mm), 2. pied hexagonal relevé (82 mm), 3. roulette (Ø 40 mm)
soporte: 1. pie hexagonal (18 mm), 2. pie hexagonal elevado (82 mm), 3. rueda (Ø 40 mm)

#01

Schiene/fianchi anche scrivibili

Backs/sides also writable
Fonds/cotés aussi à écrire
Traseras/costados también para escribir

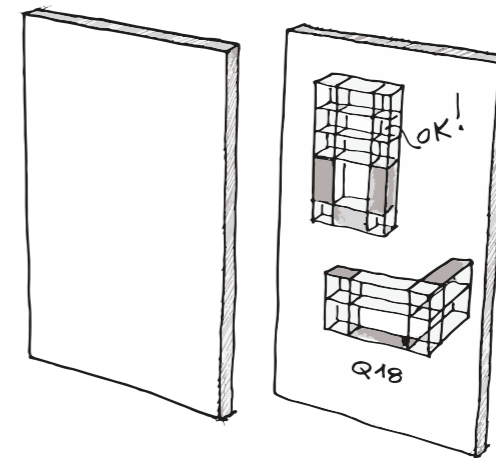

#02

Ripiani
Shelves
Tablettes
Estantes

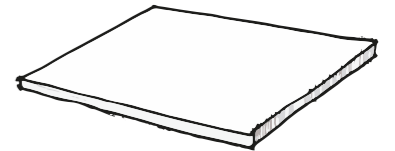

#03

Vani con anta battente o a ribalta anche scrivibili con sistema di apertura "push and pull"

Units with hinged or flap door also writable with "push and pull" opening system
Rangements avec portes battantes ou abattantes pouvant servir d'écritoire avec système d'ouverture "push and pull"
Módulos con puerta batiente o plegable también para escribir con sistema de apertura "push and pull"

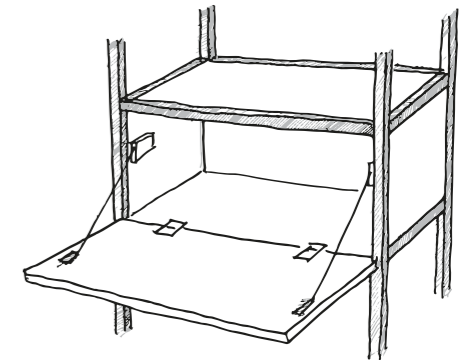
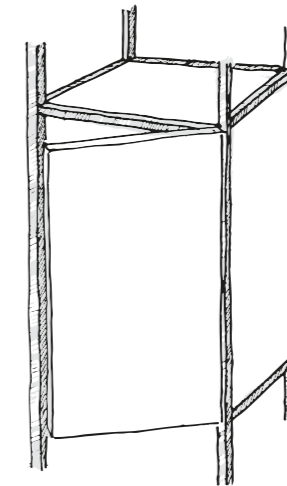
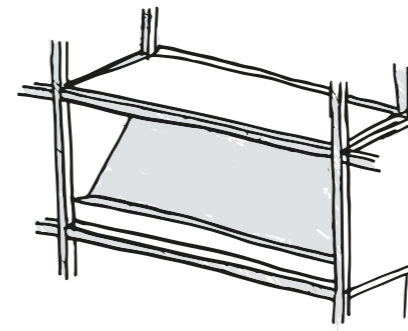

#04

Portariviste
Magazine holder
Porte-revues
Revistero

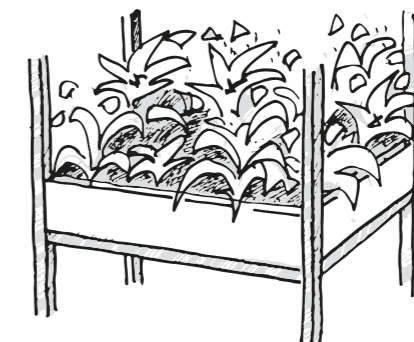

#05

Vaschette porta piante
Plant trays
Vases à plantes
Jardineras

#06

Cassetti/classificatori
Drawers/filing drawers
Tiroirs/tiroirs pour DS
Cajones/archivadores

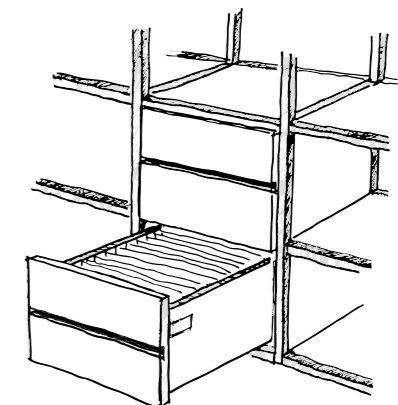
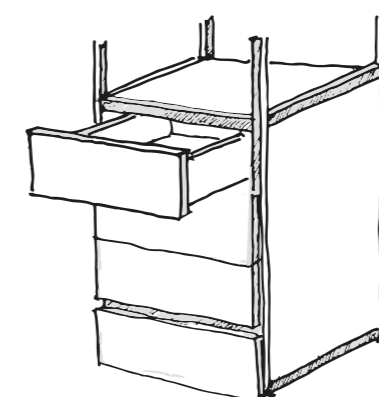

/altezze | heights | hauteurs | alturas

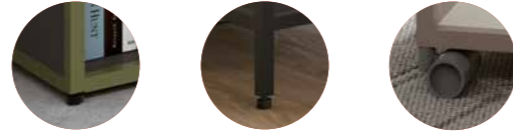

MODULO 352 mm
13 7/8"

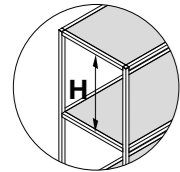

H 334 mm
13 1/8"

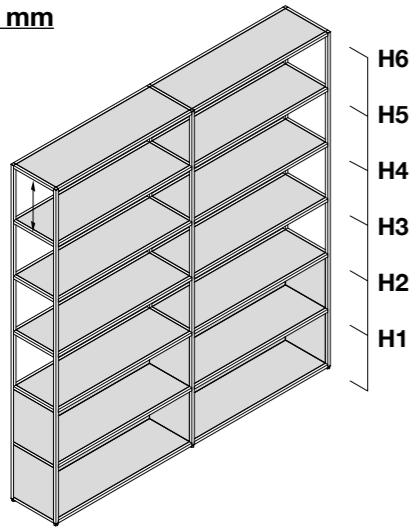

	18 mm 11/16"	82 mm 3 1/4"	44 mm 1 3/4"
H1	388 mm 15 1/4"	452 mm 17 13/16"	414 mm 16 5/16"
H2	740 mm* 29 1/8"	804 mm 31 5/8"	766 mm 30 3/16"
H3	1092 mm 43"	1156 mm 45 1/2"	1118 mm 44"
H4	1444 mm 56 7/8"	1508 mm 59 3/8"	
H5	1796 mm 70 11/16"	1860 mm 73 1/4"	
H6	2148 mm 84 9/16"	2212 mm 87 1/16"	

* Altezze per scrivanie H 740 mm | Heights for desks H 740 mm (29 1/8") | Hauteurs pour bureaux H 740 mm | Alturas para escritorios H 740 mm

MODULO 416 mm
16 3/8"

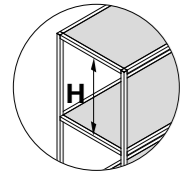

H 398 mm
15 11/16"

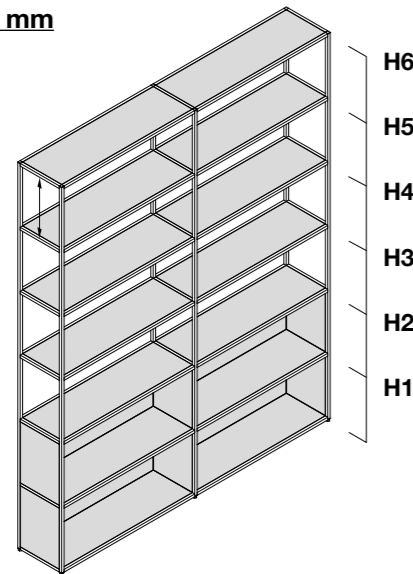

	18 mm 11/16"	82 mm 3 1/4"	44 mm 1 3/4"
H1	452 mm 17 13/16"	516 mm 20 5/16"	478 mm 18 13/16"
H2	868 mm 34 3/16"	932 mm 36 11/16"	894 mm 35 3/16"
H3	1284 mm 50 9/16"	1348 mm 53 1/16"	1310 mm 51 9/16"
H4	1700 mm 66 15/16"	1764 mm 59 3/8"	
H5	2116 mm 83 5/16"	2180 mm 85 13/16"	
H6	2532 mm 99 11/16"	2596 mm 102 3/16"	

/larghezze | widths | largeurs | anchuras

MODULO 300 mm
11 13/16"

MODULO 400 mm
15 3/4"

MODULO 500 mm
19 11/16"

MODULO 600 mm
23 5/8"

MODULO 700 mm
27 9/16"

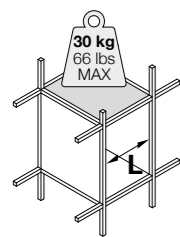

L 282 mm
11 1/8"

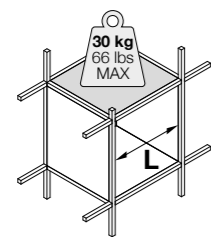

L 382 mm
15 1/16"

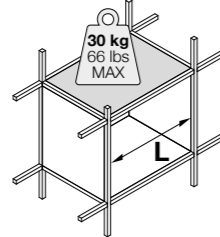

L 482 mm
19"

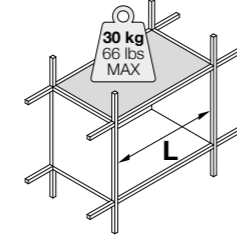

L 582 mm
22 15/16"

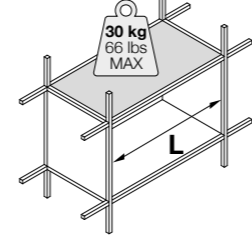

L 682 mm
26 7/8"

30 kg carico massimo per ciascuna mensola | 30 kg (66 lbs) maximum load for each shelf | 30 kg de charge maximale pour chaque étagère | 30 kg de carga máxima por cada estante

MODULO 800 mm
31 1/2"

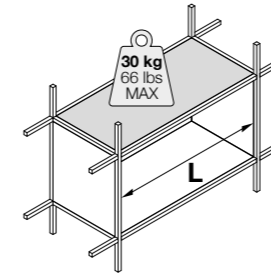

L 782 mm
30 13/16"

MODULO 900 mm
35 7/16"

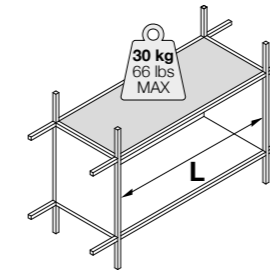

L 882 mm
34 3/4"

MODULO 1000 mm
39 3/8"

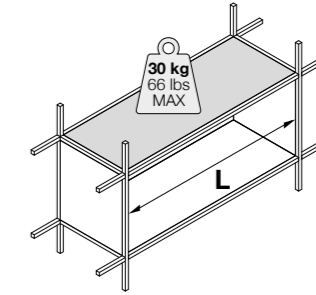

L 982 mm
38 11/16"

/profondità | depths | profondeurs | profundidades

Su piedini | on feet |
sur pieds | con pies

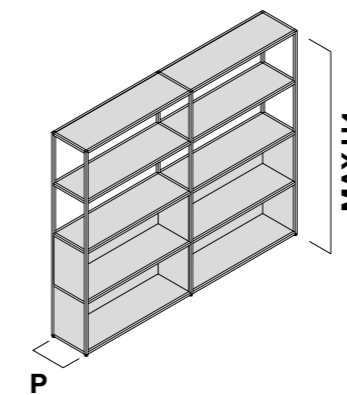

P 330 mm
13"

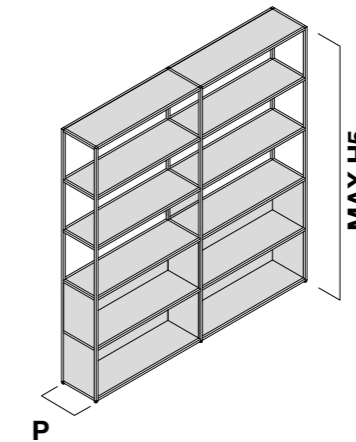

P 394 | 458 mm
15 1/2" | 18"

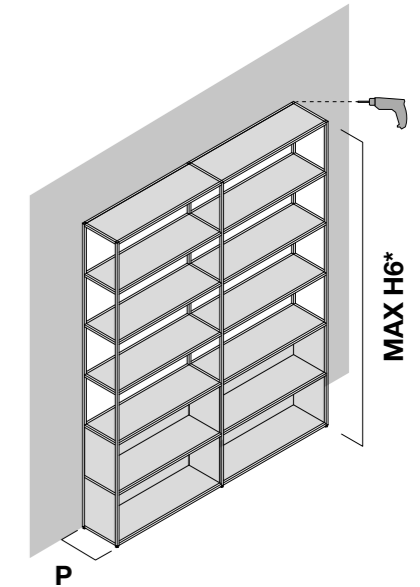

P 330 | 394 | 458 mm
13" | 15 1/2" | 18"

* Altezza massima se fissato al muro | Maximum height when fixed to the wall | Hauteur maximale en cas de fixation au mur | Altura máxima cuando se fija a la pared

Su ruote | on castors |
sur roulettes | con ruedas

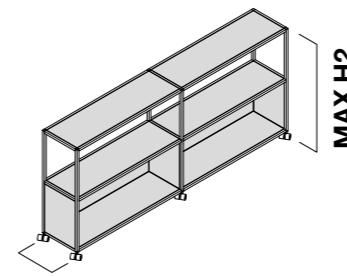

P 330 mm
15 11/16"

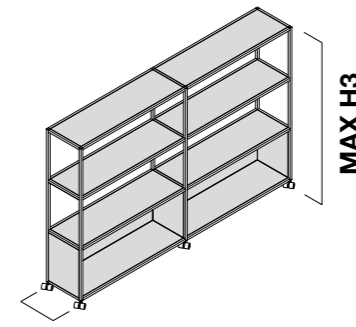

P 394 | 458 mm
15 1/2" | 18"

A soffitto | ceiling-mounted |
au plafond | en el techo

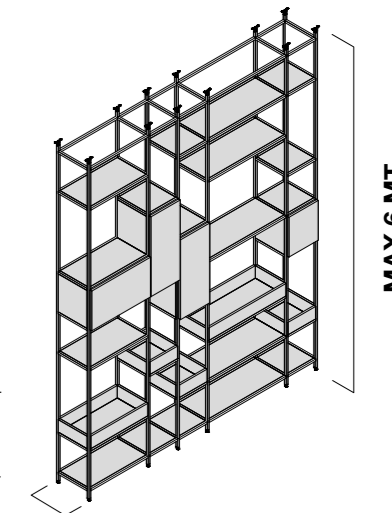

P 330 | 394 | 458 mm
13" | 15 1/2" | 18"

/configurazioni | layouts | configurations | configuraciones

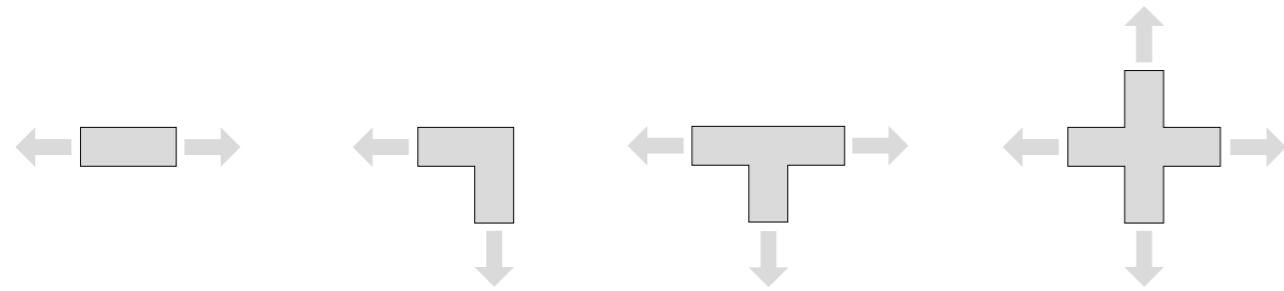



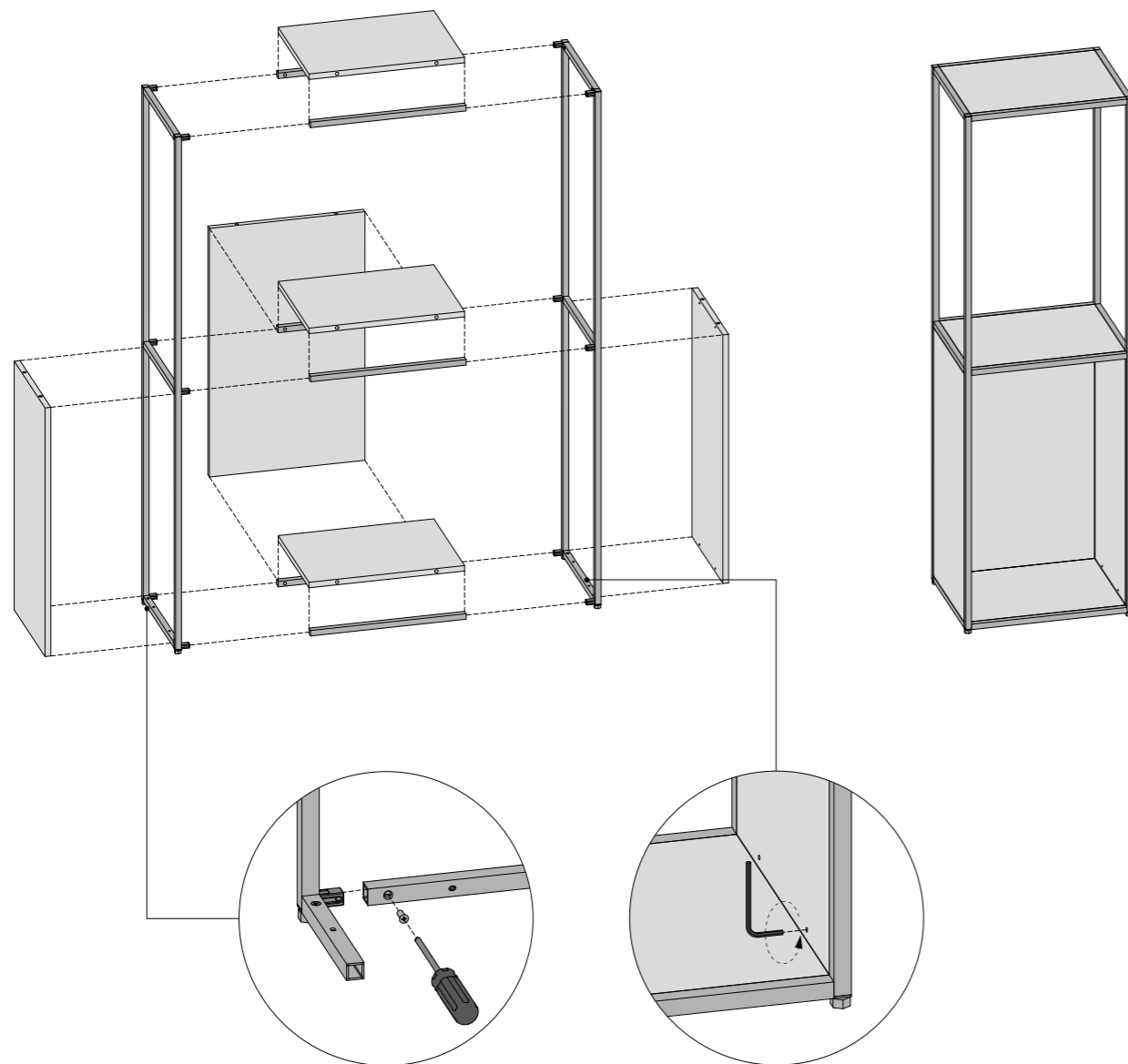







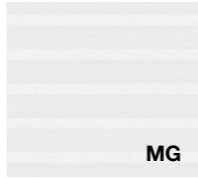
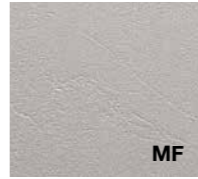

/componenti | components | composants | componentes



/finiture | finishes | finitions | acabados

MEL

Melaminico Italian melamine Mélamine Melaminico

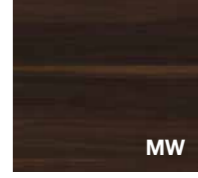
 MB	 MG	 MF	 MZ	 MN	 MT
Bianco rigato Rippled effect white Blanc avec rayures Blanco rayado	Grigio rigato Rippled effect grey Gris avec rayures Gris rayado	Nichel Nickel Nickel Niquel	Cacao Cocoa Cacao Cacao	Bianco White Blanc Blanco	Talco Talco Talco Talco
 MJ	 MK	 MI	 MD	 ML	 MC
Ocra Ochre Ocre Ocre	Safari Safari Safari Safari	Noisette Noisette Noisette Noisette	Ardesia Ardesia Ardesia Pizarra	Nero Black Noir Negro	Rovere chiaro Light oak Chêne clair Roble claro
 MY	 ME	 MM	 MO	 MW	
Rovere americano American oak Chêne américain Roble americano	Rovere grigio Grey oak Chêne gris Roble gris	Rovere moro Dark oak Chêne foncé Roble oscuro	Noce Canaletto Canaletto Walnut Noyer Canaletto Nogal Canaletto	Noce scuro Dark walnut Noyer foncé Nogal oscuro	

MEL

Melaminico scrivibile Writable melamine Mélamine à écrire Melaminico para escribir



Bianco
White
Blanc
Blanco

Le finiture contenute nella stampa sono puramente indicative e non sono di riferimento per le forniture del prodotto | Due to the printing process, finishes shown in this document are for illustration only. The finish on the final item may differ slightly from the printed illustration | Les finitions contenues dans l'impression sont purement indicatives et ne sont pas pertinentes pour les fournitures du produit | Los acabados contenidos en la impresión son puramente indicativos y no son de referencia para los suministros del producto

EPX

Epossidico Epoxy Epoxyde Epoxídico



Le immagini dei prodotti visibili all'interno di questo catalogo sono inserite a scopo puramente indicativo

The images of the products visible in this catalogue are included for information purposes only
Les images des produits visibles dans ce catalogue sont incluses à titre informatif uniquement
Las imágenes de los productos visibles en este catálogo se incluyen sólo con fines informativos

/ambiente e sicurezza | environment and safety | environnement et sécurité | medio ambiente y seguridad

ecologia

Alea utilizza per i suoi prodotti e i suoi imballi materiali facilmente separabili e riciclabili.

attestazione di prodotto

I prodotti Alea sono stati sottoposti a prove prestazionali presso laboratori di prova accreditati. Copia dei rapporti di prova o delle attestazioni di conformità sono disponibili su richiesta. I prodotti Alea soddisfano i requisiti LEED per il credito IEQ4.5 per i materiali a bassa emissione ed i requisiti ANSI/BIFMA X7.1-2011. Alea dichiara di utilizzare pannelli a base di legno aventi un rilascio di formaldeide conforme alla classe E1 secondo il DM 10/10/2008. Alea si impegna inoltre ad utilizzare materiali legnosi FSC e pannelli a base di legno con certificazione CARB2.

environment

Alea products and packaging are made of recyclable materials.

product certification

Alea products have been subjected to performance tests at accredited testing laboratories. Copies of test reports or certificates of conformity are available on request. Alea products meet the LEED requirements for IEQ4.5 credit for low emission materials and the ANSI/BIFMA X7.1-2011 requirements. Alea declares to use wood-based panels with a formaldehyde release according to class E1 according to DM 10/10/2008. Alea also undertakes to use FSC wood-based materials and CARB2-certified wood-based panels.

environnement

Alea utilise des matériaux facilement séparables et recyclables pour ses produits et ses emballages.

certification de produits

Les produits Alea ont été soumis à des tests de performance dans des laboratoires accrédités. Des copies des rapports d'essais ou des certificats de conformité sont disponibles sur demande. Les produits Alea répondent aux exigences LEED pour le crédit IEQ4.5 pour les matériaux à faibles émissions et aux exigences ANSI/BIFMA X7.1-2011. Alea déclare utiliser des panneaux à base de bois avec un dégagement de formaldéhyde selon la classe E1 selon DM 10/10/2008. Alea s'engage également à utiliser des matériaux à base de bois FSC et des panneaux à base de bois certifiés CARB2.

ecología

Alea utiliza productos y embalajes en materiales fácilmente separables y reciclables.

certificación de producto

Los productos Alea han sido sometidos a pruebas de rendimiento en laboratorios de pruebas acreditados. Copias de los informes de las pruebas o certificados de conformidad están disponibles bajo petición. Los productos Alea cumplen con los requisitos LEED para el crédito IEQ4.5 para materiales de baja emisión y los requisitos ANSI/BIFMA X7.1-2011. Alea declara utilizar paneles de madera con una emisión de formaldehído según la clase E1 según DM 10/10/2008. Alea también se compromete a utilizar materiales a base de madera FSC y paneles a base de madera certificados por CARB2.

concept & design

Alea marketing + communication

art director

Mirto Antonel

product design

Mirto Antonel & Filippin

AB/CACB/AC